

Light Pole Installation

Guidelines for Mounting of SkyPilot Devices



SkyPilot offers a comprehensive package for deploying SkyExtender series and SkyAccess DualBand devices on utility and municipal light poles. There are a number of important factors that affect these types of installations, and it is the goal of SkyPilot to assure success while reducing the time and complexity involved. This guide provides an overview of light pole installations and the methods used by SkyPilot

to qualify the solution for the rigorous demands of outdoor deployment.

Table of Contents

| | |
|---|----|
| Overview | 3 |
| Physical Specifications | 3 |
| SkyExtender Series | 3 |
| MetroPole Mount Kit | 3 |
| MetroPole Jr. Mount Kit | 4 |
| Vibration and Wind Loading | 5 |
| Overview | 5 |
| Wind Load | 5 |
| Vibration | 6 |
| Power Supply and Surge Protection | 7 |
| Overview | 7 |
| Power Supply Specifications | 7 |
| Power Supply Physical | 7 |
| Compliance | 7 |
| Surge Protection Specifications | 7 |
| Photocell Adapter | 8 |
| Adapter Specifications | 8 |
| Power Demand | 10 |
| Certifications | 10 |

Overview

The SkyExtender series is a mesh infrastructure device designed to scale the wireless network by expanding coverage throughout a deployment area. The integrated SectorSwitch antenna array allows the device to form mesh backhauls to other SkyExtender and SkyGateway nodes. As a result, no local wired connection is necessary to operate the SkyExtender other than an adequate power source, which makes the availability of municipal light poles ideal for locating SkyExtender nodes.

SkyAccess DualBand is a mesh edge device that extends and infill's Wi-Fi coverage areas. As with SkyExtender series, SkyAccess DualBand requires no local wired connection other than an adequate power source including municipal light poles.

Light poles are typically controlled by photocells, and these photocell connection points offer ready sources of power. Skypilot has designed the MetroPole and MetroPole Jr mounting kits to securely attach SkyExtender series and SkyAccess DualBand devices to light poles, and then accommodate power from a photocell connection with no interruption to the lighting control function of the photocell. For municipal deployments, the ability to utilize existing light poles and their available power significantly reduces the complexity of node installation, thereby increasing the scalability of the SkyPilot solution for citywide use by service providers.

Physical Specifications

SkyExtender Series

The SkyExtender units are cylindrical in shape with the following approximate physical attributes:

- Diameter: 12 inches (30.5 cm)
- Height:
 - 19 inches (48.3 cm) – radome only
 - 25 inches (63.5 cm) – with mount base
 - 33 inches (83.8 cm) – with antennas
- Weight: 15 pounds (6.8 kg)



MetroPole Mount Kit

The MetroPole Mount Kit offers a flexible mounting solution for SkyExtender series that is specifically designed for deployment on utility and light poles. The mounting kit (p/n 620-00708-xx) assembly consists of these components:

1. Bracket assembly – horizontal mount
2. Power supply with adapter cable
3. Surge suppressor

The bracket supports the SkyExtender device while physically attaching to the horizontal mast of a utility or light pole. A nest in the MetroPole mount kit provides a location for the placement of the SkyExtender power supply. The power supply includes a photocell adapter and surge suppressor.

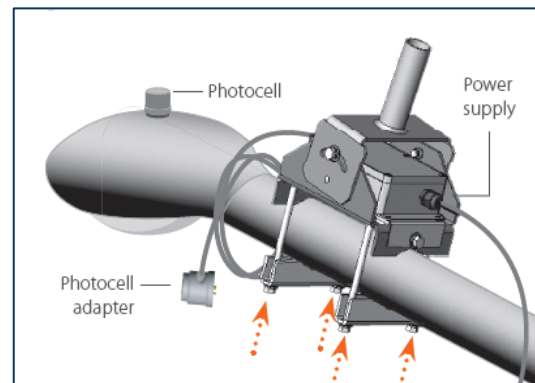

MetroPole Jr. Mount Kit

The MetroPole Jr. Mount Kit offers a flexible mounting solution for SkyAccess DualBand that is specifically designed for deployment on utility and light poles. The mounting kit (p/n 620-R0005-02) assembly consists of one component:

1. Bracket assembly – horizontal mount

This component supports the SkyAccess DualBand device while physically attaching to a horizontal mast by clamp or strap mounting methods.

Accommodation is made for the secure attachment of the SkyAccess DualBand power supply, which is available as a separate item (p/n 620-00705-xx). The power supply includes a photocell adapter and surge suppressor.

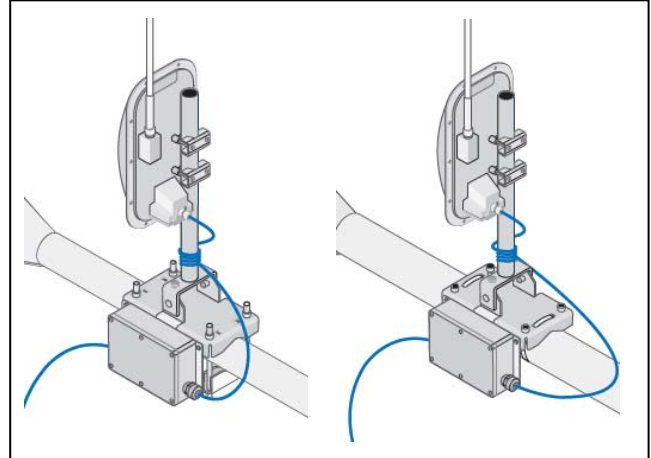

Vibration and Wind Loading

Overview

The SkyPilot MetroPole Mount Kit includes a bracket assembly and clamp, which have been designed to mount directly to the horizontal mast of a utility or light pole and withstand sustained exposure to weather conditions found in North America and abroad. The installed SkyExtender device and related MetroPole kit are exposed to significant wind load and vibration in outdoor installation conditions. Skypilot conducted independent engineering evaluations of the design to assure integrity of the assembly under both wind and vibration conditions, and the results confirm compliance with ETSI standards¹ on Environmental Tests for Stationary Use at Non-Weather Protected Locations as applicable to telecommunications equipment.

Wind Load

Skypilot requires the mounting kit assembly to withstand the loading created by 150 mph (241 Kph) winds. The cylindrical shape of SkyExtender is assessed in terms of pounds per square foot of load for continuous and non-steady (gusting) winds. Based on the dimensions of the units, the cylindrical shape has a load area equivalent to 1.60 ft² (1486 cm²), which when factored at 150 mph (241 Kph) wind speed produces a force of 117 pounds (53 kg) for the purposes of the mounting kit evaluation.

The design of each of the two mounting components has been tested separately and as an assembly. The Bracket Assembly required consideration of forces on both the weld attachment for the pole and the bracket as it attaches to the light pole. The clamp was considered for forces as it attaches to the light pole.

Results of testing for the Bracket Assembly

CERTIFIED REPORT TO: SkyPilot Networks Inc.
Submitted by Anthony Serksnis, California Professional Engineer #19484
February 20, 2006

Major items of concern with the Assembly are:

1. Weld strength of tubular pole section to bracket, and
2. Pole mount (Item 2 of Assembly) strength under the load of the screws used to attach the assembly to the horizontal member of a light Pole.

Design Basis:

SkyPilot requires that the entire Antenna Assembly (Antenna + Antenna Mounting Brackets) adequately survive the loading from:

1. 125 MPH (201Kph) wind (without exceeding Yield Strength and Fatigue Endurance Limit of the materials).
2. 150 MPH (241 Kph) wind (without exceeding the Tensile Strength of the materials).

Conclusions:

P/N 620-0076-01 ASSY, BRACKET, H-MOUNT, is adequately designed. It will not fail under wind loading on the antenna of 150 MPH (241 Kph).

¹ ETSI EN 300-019-2-4 V2.2.2 (2003-04)

Results of testing for the Clamp

CERTIFIED REPORT TO: SkyPilot Networks Inc.
 Submitted by Anthony Serksnis, California Professional Engineer #19484
 February 20, 2006

This report examines the design strength of SkyPilot P/N 508-00237-01 CLAMP, MOUNT MAIN. This clamp is attached to the antenna bottom and serves as one half of a clamp for attaching the antenna to a pole. Another (separate) piece forms the other half of the clamp.

Design Basis:

SkyPilot requires that the entire Antenna Assembly (Antenna + Antenna Mounting Brackets) adequately survive the loading from:

1. 125 MPH (201Kph) wind (without exceeding Yield Strength and Fatigue Endurance Limit of the materials).
2. 150 MPH (241 Kph) wind (without exceeding the Tensile Strength of the materials).

Conclusions:

The Clamp, 508-00237-01, is adequately designed. It will not fail under wind loading on the antenna of 150 MPH (241Kph).

Vibration

Skypilot requires the MetroPole Mount Kit with SkyExtender to meet adequate requirements for vibration. Tests were conducted according to IEC 60721-3-4 procedures. Both sine swept vibration and random vibration tests were performed.

Materials:

- SkyExtender DualBand
- MetroPole Mount Kit (PN 620-00705-01, r1)

Testing:

The SkyExtender DualBand was verified before vibration testing to be in proper running order. The unit was tested to the requirements of IEC 60721-3-4, Class 4M3 in both the X and Y axis. Both the sinusoidal and random vibration tests were performed.

Conclusions:

The unit was still in its original position after all tests and no parts were broken or loose on either the mounting bracket or SkyExtender device itself. After the SkyExtender was brought back to the lab it was powered up and operation of the unit was normal. The design of the SkyExtender and MetroPole bracket meet the vibration requirements of ETSI EN 300 019-2-4.



Power Supply and Surge Protection

Overview

The SkyExtender series and SkyAccess DualBand can be operated directly from available power if the light pole utilizes a photocell. The photocell power connection eliminates the need for installing dedicated power cabling at the pole location. Included with the device is a power supply that connects via Power over Ethernet (PoE), and then is connected to the photocell using an adapter for system power. The complete assembly is designed for outdoor exposure to weather, and consists of one component:

POWER SUPPLY/POE INJECTOR (P/N 510-R0002-xx)

Power Supply Specifications

- Input Voltage Operating Range: 90-264VAC 50/60Hz +/-3Hz
- Output Voltage: 24 VDC +/- 2%
- Output Current: 1.25 AMPS (approx 30 W)
- Input To Output Isolation Voltage: 3,000Vrms (Minimum)
- Input To Ground Isolation: 2,000Vrms (Minimum)
- Output Isolation: 500Vrms (Minimum) from DC Output and DC Output Return to Protective Earth
- Load Regulation: +/- 2% (can support up to 5% if cost savings)
- Output Noise And Ripple: 100mV (peak-to-peak max)
- Isolation Resistance Input/Output: 500Mohms
- Input Circuit Protection: Dual Fusing CC Class (not serviceable)
 - Over current protection non-latency mod

Power Supply Physical

- Maximum Overall Dimensions:
 - Max Length: 6.75 inches (171.5 mm)
 - Max Width: 4.75 inches (120.6 mm)
 - Max Height: 2.25 inches (57.2 mm)
- Storage Temperature: -40 C to 85 C (-40 F to 185 F)
- Operating Temperature: -40 C to 65 C (-40 F to 149 F)
- Humidity Range: 5 - 100% non-condensing
- Weather Protection: NEMA 4X
- Mechanical Shock And Vibration: per ETS1 300-19-2-4
- Cooling: Cools by convection only

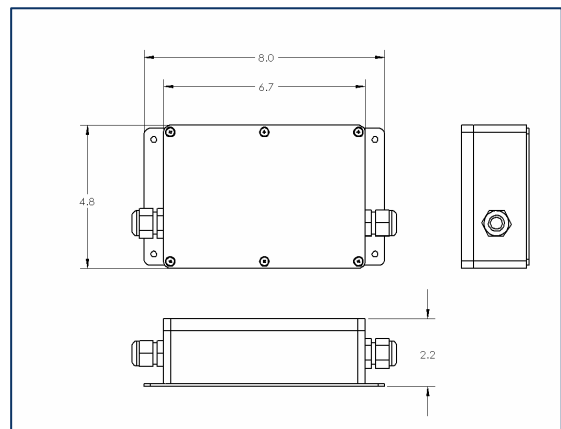

Compliance

ANSI 136.10 compliant

Surge Protection Specifications

- Input Surge Protection: Hybrid MOV / Gas Discharge Tube - 8/20uS Waveform 30kA per phase L-N, N-PE, L-PE

- o IEEE C62.41 CLASS C.A ENVIRONMENT: – 6kV/5kA 8/20uS Waveforms

Photocell Adapter

The power supply can be connected directly to the photocell socket, and includes an adapter to mate with the receptacle. The photocell can then be connected to a matching receptacle on the top of the power supply adapter to maintain functionality of the photocell.

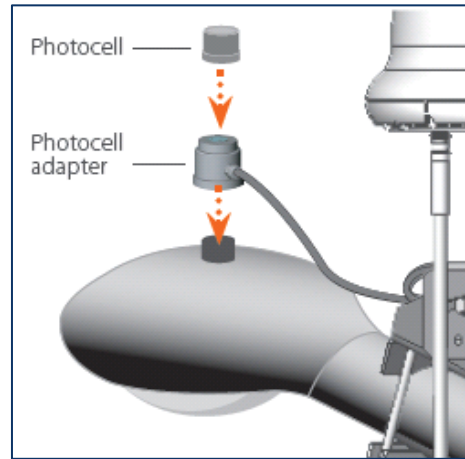
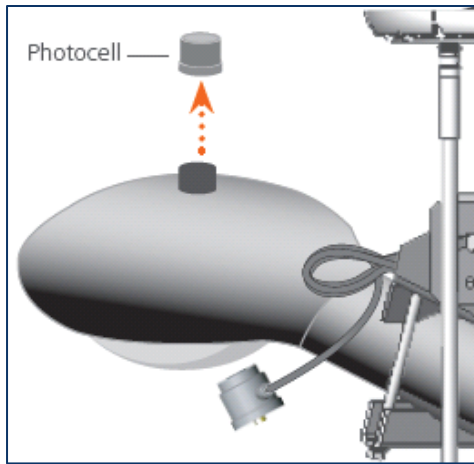

Adapter Specifications



| | |
|--------------------------|--|
| Nominal Voltage 50/60 Hz | 120 |
| Voltage Range | 105–135 |
| Base | Standard 3-prong twist-lock per ANSI C136.10 |
| Housing | 3-1/2" Diameter ABS |
| Cord | 2-1/2 Feet Long with 3-prong receptacle |
| Circuit Breaker | 10 amp, auto-reset |
| Load Rating | 10 amp |
| Operating Temperature | -40C to +70C (-40F to +158F) |
| Photocontrol | Not Included Sold separately |
| Dielectric Strength | 5000 Volts between current carrying parts and metal surfaces |

Power Demand

The SkyExtender and SkyGateway series devices have varying power demands depending on the specific model and traffic throughput at the particular node location. The following table provides a reference for expected power draw. The voltage is constant at 24V DC under all conditions.

| | SkyGateway / SkyExtender | SkyGateway / SkyExtender Dual Band | SkyGateway / SkyExtender Tri Band |
|------------------------|--------------------------|---------------------------------------|--------------------------------------|
| Links Only | 0.28 A / 6.7 watts | 0.46 A / 11.0 watts | 0.53 A / 12.7 watts |
| Moderate Traffic | 0.42 A / 10.1 watts | 0.59 A / 14.2 watts | 0.7 A / 16.8 watts |
| Heavy Traffic | 0.44 A / 10.6 watts | 0.61 A / 14.6 watts | 0.8 A / 19.2 watts |
| Heavy Traffic (winter) | 0.64 A / 15.4 watts | 0.83 A / 19.9 watts | 1.0 A / 24.0 watts |

Certifications

SkyPilot solutions have met all applicable regulatory and safety standards for wireless transmitting equipment, including the following certifications. The official reports may be reviewed in their entirety by accessing SkyPilot's secure Support page.

- FCC Part 15, FCC 47 CFR Part 15, Class B USA
- UL
- CE
- C-Tick
- ICRSS210 Issue 5

EMI Susceptibility

- FCC Part 15.107 and 15.109

© 2007 SkyPilot Networks, Inc. All rights reserved. SkyGateway, SkyExtender, SkyConnector, SkyControl, SkyAccess, SyncMesh, SkyPilot, SkyPilot Networks, SkyProvision, the SkyPilot logo, and other designated trademarks, trade names, logos, and brands are the property of SkyPilot Networks, Inc. or their respective owners. Product specifications are subject to change without notice. This material is provided for informational purposes only; SkyPilot assumes no liability related to its use and expressly disclaims any implied warranties of merchantability or fitness for any particular purpose.



Leading the Mesh Revolution

2055 Laurelwood Road
 Santa Clara, CA 95054-2747
 408.764.8000
 US Toll Free 866 SKYPILOT
 sales@skypilot.com